

JBL

Bass2/Basswave

Powered Subwoofer

TECHNICAL MANUAL

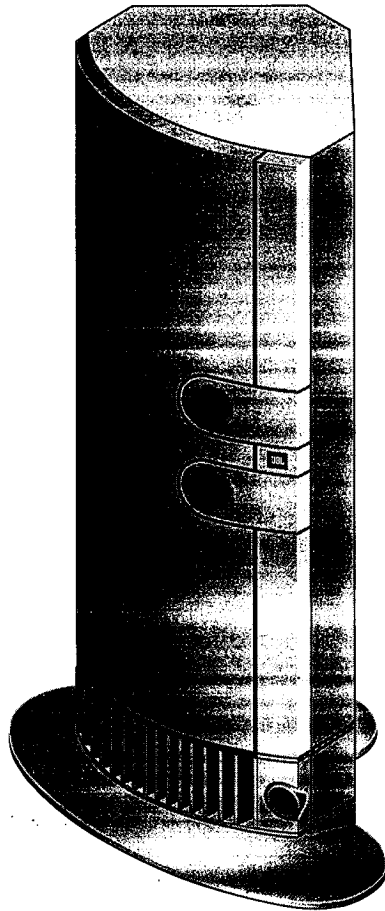

JBL Consumer Products Inc.
80 Crossways Park West
Woodbury, N.Y. 11797
1-800-336-4JBL in the USA

H A Harman International Company

Part No.: 1112-BASS2/BASSWAVE

TABLE OF CONTENTS

| | | | |
|-----------------------------------|---|-----------------------------------|---|
| Specifications | 1 | Test Procedure | 4 |
| Features..... | 1 | Wiring Diagram..... | 5 |
| Disassembly Procedures..... | 2 | Parts Lists..... | 6 |
| Packaging Exploded View | 2 | Integrated Circuit Diagrams | 7 |
| Bass2/Basswave Exploded View..... | 3 | Schematic Diagrams | 8 |

SPECIFICATIONS

Nominal Impedance: 4 ohm
 Amplifier Power: 100W Continuous
 Sensitivity: 90 dB SPL*
 Crossover Frequency: 120 Hz (Nominal)
 Frequency Response: 40 Hz to 120 Hz (+/-3 dB)
 Amplifier Input Impedance: 48k ohm(Line)/1k ohm (Speaker)

External Dimensions

Height 28.17" (716mm)
 Width 10.25" (260mm)
 Depth 12.05" (306mm)
 Shipping Weight 32 lbs (14.5 kg)

Aural Sweep Test Specifications:

- A. System Aural Sweep Test: . . 5.0V Input, 10 Hz to 1 kHz
- B. L.F. Aural Sweep Test: 5.0V Input, 10 Hz to 1 kHz

*1 Watt @ 1 Meter

FEATURES

- The Bass2/Basswave powered subwoofer is part of the MUSIC 2 System.
- 100 watt output.
- Variable level control.
- Line level and speaker level inputs.
- User friendly "auto on" circuit. Signal sensing automatically turns the subwoofer on so you don't have to; the subwoofer is meant to be left "on" without use of a power switch*
- Speaker is magnetically shielded for use near televisions or computer monitors.

* Early versions of the Bass2/Basswave will cycle into a standby mode when the signal source is absent after a predetermined time; the green LED turns OFF when this happens on the 120 volt version, the LED cycles to RED on the 230 volt version. The subwoofer's sensitivity to input signals was increased in later versions and these units stay ON, even when the input signal is absent. This is a normal condition, and does not compromise the safety, integrity, or dependability of the product in any way.

DISASSEMBLY PROCEDURE

To Access Amp. Circuit Boards

1. Remove (4) base screws; remove base.
2. Remove (2) large 1/4-20 Torx #30 amp mounting screws from amplifier bottom.
3. Remove amp assembly from cabinet; unplug the (2) output wires.
4. Remove the (4) Torx #15 screws from top plate.
5. Remove/scrap adhesive away from the strain relief plug area in the top cover.
6. Pry strain relief plug from top cover; remove cover.

To Access Lower Woofer

1. Remove (4) base screws; remove base.
2. Remove (2) large 1/4-20 Torx #30 amp mounting screws from amplifier bottom.
3. Remove amp assembly from cabinet.
4. Unplug the (2) wires from woofer; remove the (4) 8 x 3/4 Phillips screws from the inner baffle.
5. Remove woofer.

NOTES:

1. *The upper woofer is non-serviceable. Order replacement cabinet/upper driver assy. (Part # BASSWAVEENCLKIT)*
2. *A NEW AMP GASKET, (Part # 75140), between amp and cabinet is recommended to ensure airtight seal if the amplifier is removed for any reason.*
3. *If amplifier is serviced for any reason: after the strain relief plug is inserted back in top cover, an adhesive, e.g. hot melt glue, silicon seal, epoxy or similar product must be used on the strain relief junction to ensure an air tight seal.*

PACKAGING EXPLODED VIEW

Warranty 76310
Owner's Manual 76309-07

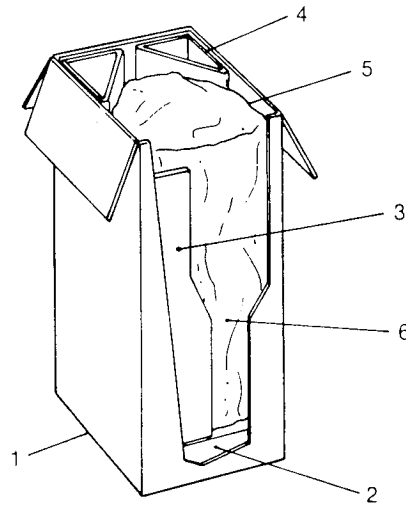

- 1 Carton, 75831
- 2 End Pad (2), 75832
- 3 Filler, 76057
- 4 Filler, Corrugated (2), 76363
- 5 Installation Kit, 76217-02
- 6 Polybag, 64222

JBL continually strives to improve its products. New materials, production methods and design refinements are introduced into existing models without notice as a routine expression of our design philosophy. For this reason, the Bass2/Basswave Subwoofer may differ in some respect from its published specifications and descriptions, but will always equal or exceed the original specifications unless otherwise stated.

BASS2/BASSWAVE EXPLODED VIEW

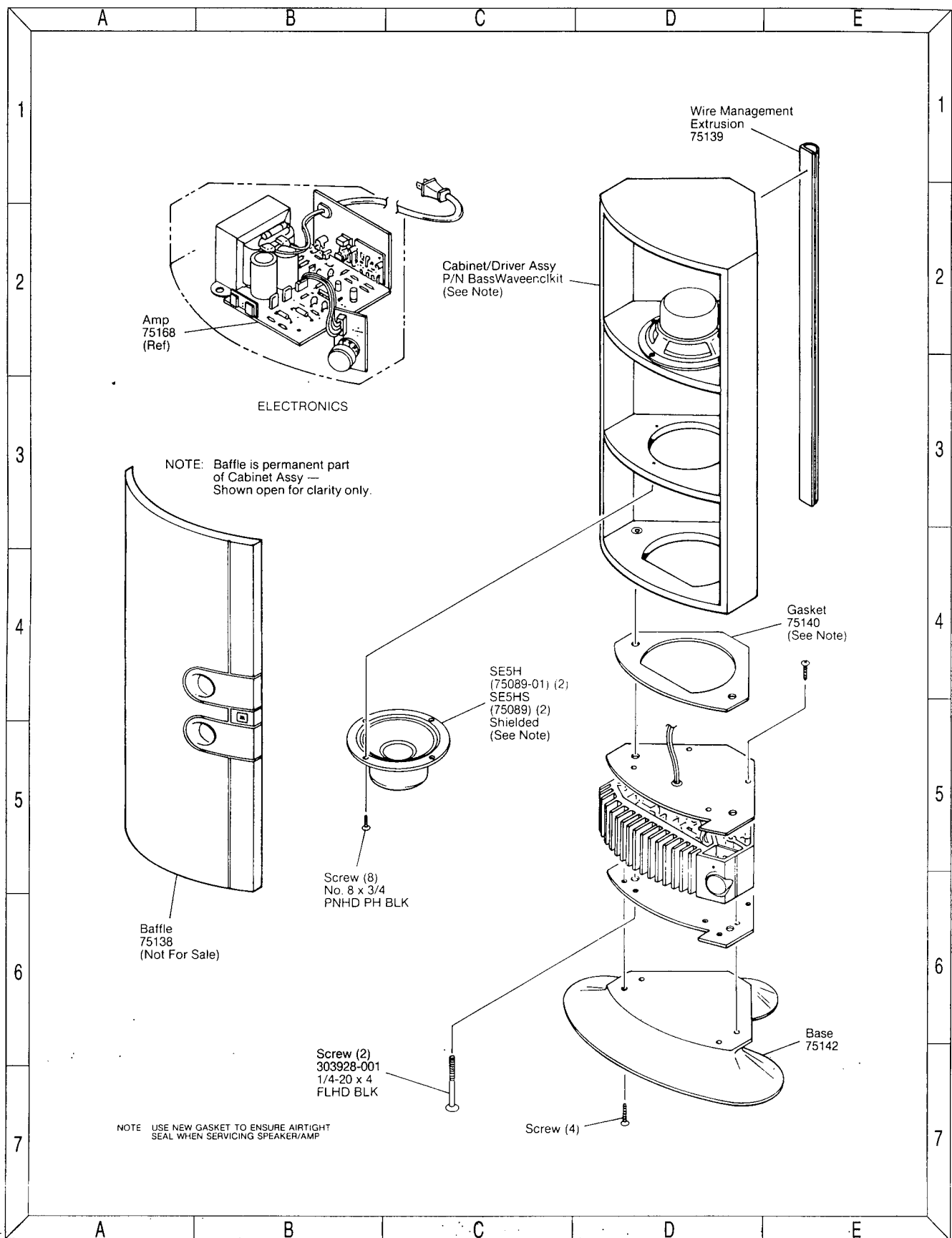

TEST PROCEDURES

Equipment needed:

- Functional/signal generator
- True RMS Multimeter
- Integrated amplifier
- Cables - line level (RCA) and speaker cables
- RCA Y-cable

General Function

UUT = Unit Under Test

1. Connect both right and left line level inputs (RCA) to signal generator and UUT. Assure input button is in depressed position. Use Y-cable if necessary from mono source.
2. Turn on generator, adjust to **50 mV, 50 Hz**. Plug in UUT, turn level control full clockwise.
3. Green LED should light, immediate bass response should be heard and felt from port tube openings.
4. Turn off generator, unplug unit, disconnect RCA cables.
5. Connect two pair of speaker cables to high level input terminal on UUT. Assure input button is in extended (out) position. Cables should be connected to an integrated amplifier fed by the signal generator. Observe polarity of speaker cables.
6. Turn on generator and adjust so that speaker level output is **2.0V, 50 Hz**. Plug in UUT, turn level control full clockwise.
7. Green LED should light, immediate bass response should be heard and felt from port tube openings.

Sweep Function

1. Connect both right and left line level inputs (RCA) to signal generator and UUT. Assure input button is in depressed position. Use Y-cable if necessary from mono source.
2. Turn on generator, adjust to 50 mV. Plug in UUT, turn level control full clockwise.
3. Green LED should light, immediate bass response should be heard and felt from port tube openings.
4. Sweep generator from 20 Hz to 300 Hz. Listen to the cabinet and drivers for any rattles, clicks,

buzzes or any other noises. If any unusual noises are heard, remove driver and test.

Driver Function

1. Follow instructions on page 2 ("To Access Lower Woofer").
2. Check DC resistance of driver; it should be approximately **5.2 ohms**. Upper (non-removable) driver can be checked by disconnecting both the wires to the amplifier and the lower driver, then connecting the test meter to the wires.
3. Connect a pair of speaker cables to driver terminals. Cables should be connected to an integrated amplifier fed by a signal generator. Turn on generator and adjust so that speaker level output is **4.0V**.
4. Sweep generator from **20 Hz to 1KHz**. Listen to driver for any rubbing, buzzing, or other unusual noises.

*** The upper woofer in non-serviceable. Order replacement cabinet/upper driver assy. (Part#BASSWAVEENCLKIT). Also cone/diaphragm kits not available, defective drivers should be replaced.**

Service Notes/Revisions

In the event you receive a unit with the complaint that the unit "shuts down after it is on for a while", usually about 10-15 minutes. (Verify the R46 has not been changed with a jumper already; then proceed with modification of the amplifier unit).

This should be performed on units with circuit board marked Rev. 001 to Rev. 003.

If you have found output devices Q4 or Q5 shorted, replace with matched pairs only. This is critical for proper amplifier operation.

Procedure: Locate R46 (33 ohm) and replace it with a 22 gauge jumper wire. After verifying normal turn-on, load the amp with a 4 ohm watt resistor and apply a 70 Hz, 200 mV signal to one RCA input jack. Let the amp run for about 20 minutes to confirm the amp no longer shuts down.

Additional Service Notes/Revisions

Customers who complain of a low level distortion heard only during very quiet musical passages, or experience erratic/inconsistent turn-on performance may need to have their units modified as follows:

1. Remove jumper wire JW12.
2. Change resistor R24 to a 22k ohm, 5%, 1/8W. (JBL part# HM185-02202-00).
3. Change capacitor C19 to a .0047 uf cap. (JBL part# 3679472120).
4. Cut trace at SW1 (middle pin which runs to JW12).
5. Add 2" insulated jumper wire from SW1 (middle pin) to right-hand side of JW12. Route this jumper away from the four large diodes.
6. Add an uninsulated jumper from the left-hand side of JW12 to the ground trace which runs just to the right of it.

Serial numbers below should already be modified.

| 100v | 120v | 230v |
|-------------------------|--|---|
| JSEKE10988 and above | JSEKD13486 and above JSEL027239 and above | JSEKF20034 and above JSELF020498 and above |

Early versions of the units ending with serial #JSELD 024124 had a 18VDC output jack; later versions are missing this. It's presence or absence does not affect subwoofer operation in any way.

Early versions of the units below serial # JSELD 024125 will cycle into a standby mode when the signal source is absent after a predetermined time; the green LED turns OFF when this happens on the 120 volt version, the LED cycles to RED on the 230 volt versions. The unit's sensitivity to input signals was increased on serial # JSELD 024125 and above; these units may stay ON, even when the input signal is absent. This is a normal condition, and does not compromise the safety, integrity, or dependability of the product in any way. The standby condition that took place on earlier versions was an electronic muting, and both versions draw the same amount of power at all times, whether muted or ON.

NOTE: If a customer (of a later revision) is insistent that the auto-mute feature work on his subwoofer, an easy way to accomplish this is to use the speaker level (high level) inputs on the unit in lieu of the RCA jacks.

WIRING DIAGRAM

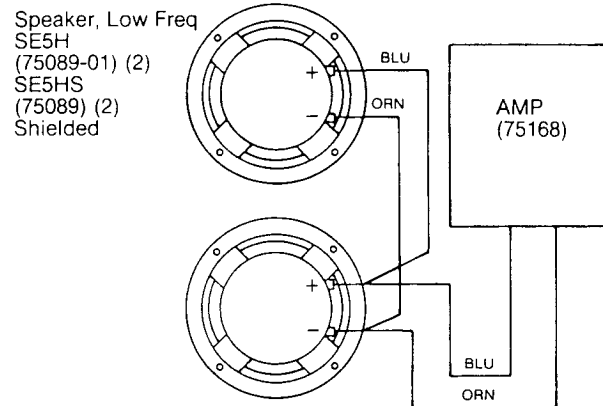

BASS2/BASSWAVE PARTS LIST

ELECTRICAL PARTS LIST

| Ref. Number | Part Number | Description | Quantity |
|----------------------|----------------|--------------------------------|----------|
| Capacitors | | | |
| C1 | HM14-0682 | 0.022 μ f, 5%, 50V | 1 |
| C3, 4 | HM14-0600 | 10 μ f, 50V, RL | 2 |
| C5 | 14-0744 | EL, 4.7 μ f, 50V, RD | 1 |
| C6, 7 | C14-0646 | EL, 100 μ f, 10V, RAD | 2 |
| C9 | 14-0603 | EL, 100UF, 20%, 25V, RD | 1 |
| C12 | HM14-0581 | SF, 0.047 μ f, 5%, 50V | 1 |
| C13 | HM14-0727 | CD, 100 μ f, 5%, 100V | 1 |
| C14 | 14-0632 | CD, 10 μ f, 10%, 500V | 1 |
| C15 | HM14-0740 | CD, 470 μ f, 5%, 100V, 5E | 1 |
| C16 | HM14-0592 | SF, 0.01 μ f, 5%, 50V, RAD | 1 |
| C17, 18 | 282778-001 | EL, 4700 μ f, 50V, RAD | 2 |
| C19 | HM14-0677 | SF, 0.0018 μ f, 5%, 50V | 1 |
| C20 | HM14-0582 | SF, 0.1 μ f, 5%, 50V | 1 |
| Diodes | | | |
| CR1, 2, 3, 4 | 13-0719 | RECT, 3A, 200V 1N5402 | 4 |
| CR5, 8, 11 | C13-0482 | GP, 1N4148 | 3 |
| CR6, 7 | 13-0357 | ZR, 1N4744A, 15V, 10%, 1W | 2 |
| Miscellaneous | | | |
| CR10 (230V) | 283025-002 | LED, BI-COLOR, T1, FLH, 230V | 1 |
| (120V) | 283025-001 | LED, GREEN, T1, FLH, 120V | 1 |
| J1 | 282558-001 | JACK, 2P, RCA, PCMT, GOLD | 1 |
| J2 | 282646-001 | TERM, 4P, PCMT | 1 |
| JW1-5, 7-14 R46 | 99-0183 | WIRE, BUSS, 22G, SOLID | 2.31ft |
| SW1 | Z100-5003 | SWITCH 4 KNOB, K100-1009 | 1 |
| TH1 | S200-0161 | POSISTOR, 50C | 1 |
| Transistors | | | |
| Q1 | HM13-0413 | T0-92, NPN, 2N3904 | 1 |
| Q2 | 13-0632 | TIP31C, NPN, 100V | 1 |
| Q3 | 13-0633 | TIP32C, PNP, 100V | 1 |
| Q4 | S225-1515 | TIP36C, PNP, SGS | 1 |
| Q5 | S225-1517 | TIP35C, NPN, SGS | 1 |
| Q6 | 13-0270 | FET, J112, N-CH, T0-92 | 1 |
| Resistors | | | |
| R2 | HM185-1000-00 | 0 Ω , 5%, 1/8W | 1 |
| R3 | 50180-019 | MF, 150k, 1%, 1/8W | 1 |
| R6 | HM185-01001-00 | CF, 1k, 5%, 1/8W | 1 |
| R7 | 50392-020 | CF, 430 Ω , 5%, 1/8W | 1 |
| R8, 35 | C185-03301-00 | CF, 3.3k, 5%, 1/8W | 2 |
| R9, 10 | 282789-001 | MF, 470 Ω , 5%, 3W, SWL | 2 |
| R11, 14, 19 | 50180-135 | MF, 49.9k, 1%, 1/8W | 3 |

| Ref. Number | Part Number | Description | Quantity |
|-----------------|----------------|--------------------------------|----------|
| R12, 13, 16, 17 | 307972-001 | MF, 511-OHM, 1%, 1/2W | 4 |
| R15 | 282822-001 | MF, 12.1-OHM, 1%, 1/4W | 1 |
| R18 | 282833-001 | MF, 16.5 Ω , 1%, 1/4W | 1 |
| R20, 23 | C185-010000-00 | CF, 100 Ω , 5%, 1/8W | 2 |
| R21, 34 | 185-03303-00 | CF, 330k, 5%, 1/6W | 2 |
| R22 | C185-02200-00 | CF, 220 Ω , 5%, 1/8W | 1 |
| R41 | 185-04702-00 | CF, 47k, 5%, 1/6W | 1 |
| R24 | 185-04702-00 | CF, 20k, 5%, 1/8W | 1 |
| R25 | HM185-02201-00 | CF, 47k, 5%, 1/6W | 1 |
| R26 | 50180-177 | MF, 147k, 1%, 1/8W | 1 |
| R27 | HM185-01102-00 | CF, 11k, 5%, 1/8W | 1 |
| R28 | HM185-08200-00 | CF, 820 Ω , 5%, 1/8W | 1 |
| R29, 32 | HM184-01001-00 | MF, 1k, 1%, 1/4W | 2 |
| R30 | 187-00057-00 | WW, 33 Ω , 5%, 3W | 1 |
| R31 | 282809-001 | MF, 330 Ω , 5%, 3W, SML | 1 |
| R33, 39 | HM185-02202-00 | CF, 22k, 5%, 1/8W | 2 |
| R36 | 185-01005-00 | MF, 10MEG, 5%, 1/6W | 1 |
| R37 | VP70007-185 | 1.8MEG, 1/8W | 1 |
| R38, 40 | HM185-01002-00 | CF, 10k, 5%, 1/8W | 2 |
| R42 | HM185-01004-00 | CF, 1MEG, 5%, 1/8W | 1 |
| R45 | 181-02201-00 | CF, 2.2k, 5%, 1/4W | 1 |
| R44, 47 | 282809-001 | MF, 330 Ω , 5%, 3W, SML | 2 |

Transformers

| | | | |
|----|------------|--------------------------|---|
| T1 | 282459-004 | TRANSFORMER 120V 60Hz | 1 |
| T1 | 282459-002 | TRANSFORMER 230V 50Hz | 1 |
| T1 | 282459-003 | TRANSFORMER 100V 50/60Hz | 1 |

Integrated Circuits

| | | | |
|----|---------|-----------------------|---|
| U1 | 13-0217 | TL074, QUAD, OP-AMP | 1 |
| U2 | 13-0304 | TL072CP, OP-AMP, DUAL | 1 |

INTEGRATED CIRCUIT DIAGRAMS

U1 - TL074 OP AMP (1/4 SHOWN)

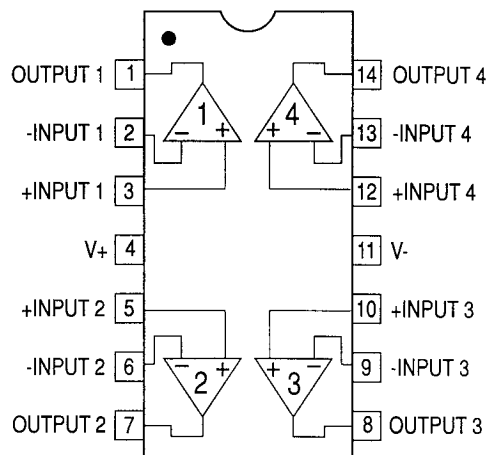
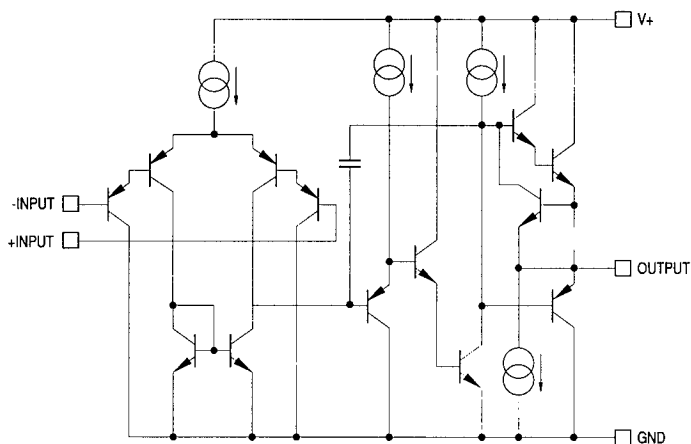

U2 - TL072CP OP AMP (1/2 SHOWN)

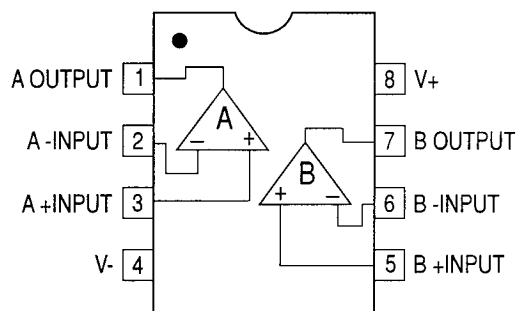
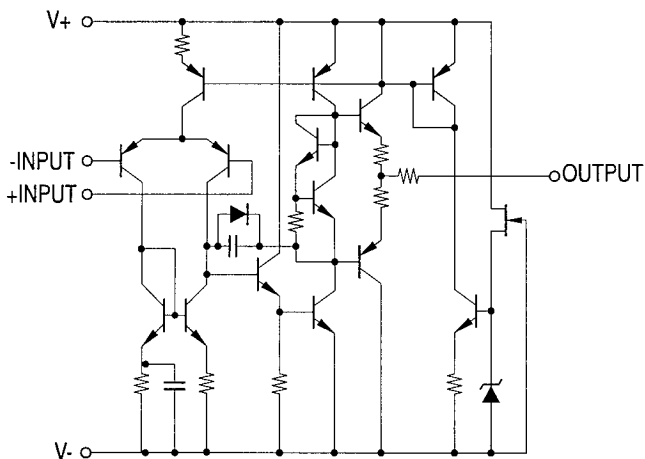

- Q2 - TIP 31C
- Q3 - TIP 32C
- Q4 - TIP 36C
- Q5 - TIP 35C

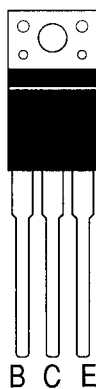

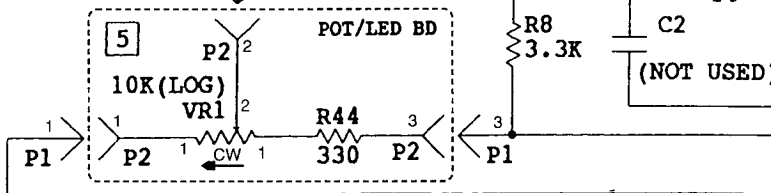
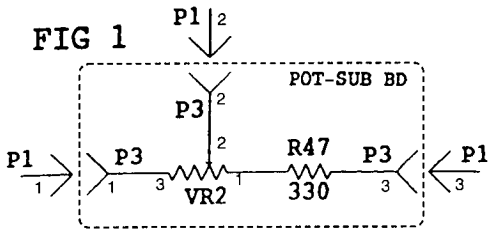
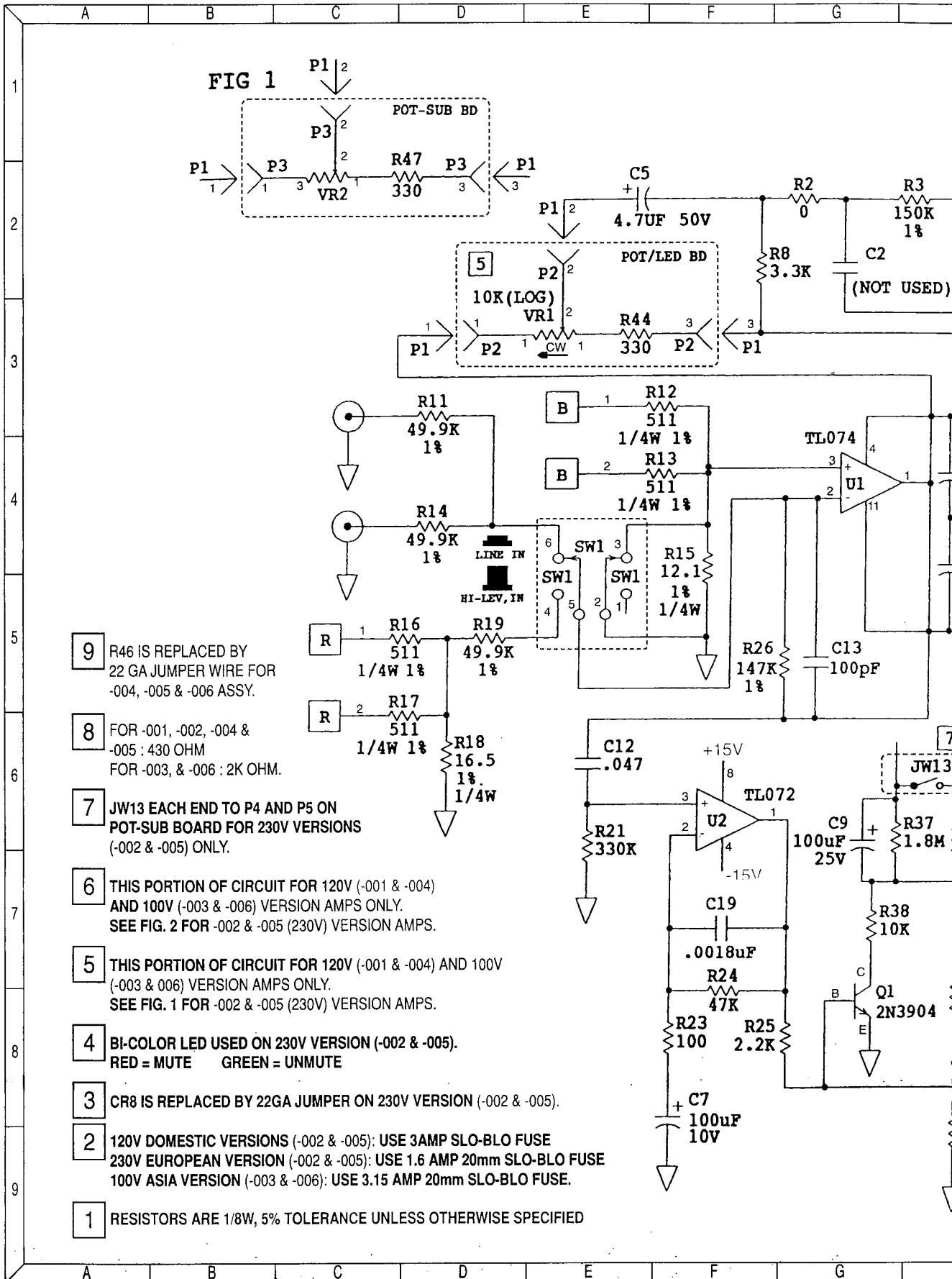

- 9 R46 IS REPLACED BY 22 GA JUMPER WIRE FOR -004, -005 & -006 ASSY.
- 8 FOR -001, -002, -004 & -005 : 430 OHM FOR -003, & -006 : 2K OHM.
- 7 JW13 EACH END TO P4 AND P5 ON POT-SUB BOARD FOR 230V VERSIONS (-002 & -005) ONLY.
- 6 THIS PORTION OF CIRCUIT FOR 120V (-001 & -004) AND 100V (-003 & -006) VERSION AMPS ONLY. SEE FIG. 2 FOR -002 & -005 (230V) VERSION AMPS.
- 5 THIS PORTION OF CIRCUIT FOR 120V (-001 & -004) AND 100V (-003 & 006) VERSION AMPS ONLY. SEE FIG. 1 FOR -002 & -005 (230V) VERSION AMPS.
- 4 BI-COLOR LED USED ON 230V VERSION (-002 & -005). RED = MUTE GREEN = UNMUTE
- 3 CR8 IS REPLACED BY 22GA JUMPER ON 230V VERSION (-002 & -005).
- 2 120V DOMESTIC VERSIONS (-002 & -005): USE 3AMP SLO-BLO FUSE 230V EUROPEAN VERSION (-002 & -005): USE 1.6 AMP 20mm SLO-BLO FUSE 100V ASIA VERSION (-003 & -006): USE 3.15 AMP 20mm SLO-BLO FUSE.
- 1 RESISTORS ARE 1/8W, 5% TOLERANCE UNLESS OTHERWISE SPECIFIED

Basswave Schematic Diagram

